



 VT LeeBoy
A company of VT Systems

600 Series Motor Graders

685C Motor Grader



685C Motor Grader

Performance features include:

- 110 hp (82.1 kw) Cummins Tier 3 Diesel Engine
- 11' (3.35 m) Sliding Moldboard
- Tandem Gear Drive
- Electronic Gauge Package
- Fail Safe Braking
- Two-speed Hydrostatic Transmission
- Side Shift Reach to 3' (0.91 m)
- Vandalism Protection Package
- Rear Mount Scarifier
- Cab or Canopy Configuration
- Tandem or Front Wheel Assist

Best in Class



Power and Economy in a Mid-Sized Grader

The 685C Motor Grader is designed to deliver power, performance and durability at the jobsite.

Whether building a road, cutting a ditch, preparing a work site or doing fine grading, the LeeBoy 685C Motor Grader is a versatile workhorse and features operator comfort and safety, easy control, and trouble-free operation.



11-Foot Sliding Moldboard



The optional 7' (2.13 m) front blade gives the operator an additional tool for grading in hard to reach areas, such as corners or against walls. (Shown here with wheel lean.)

The 685C Motor Grader is equipped with a sliding/tilting moldboard with a total side shift of 3' (0.91 m). This feature enables the operator to shift the blade in or out of hard to reach areas. The circle shift option provides the operator with additional moldboard reach. The 11' (3.35 m) wide moldboard features removable and adjustable shims that keep the blade tight for fine grading.

Premium Power Train

Efficient Turbo Diesel Engine

The 685C Motor Grader is powered by a 110 hp (82.1 kw) Cummins Tier 3 turbo diesel engine.

Drive System

The tandem gear drive system utilizes a hydrostatic transmission with oversized, off-road, Dana two-speed gear box and no-spin differential. Smooth gear and direction changes result.



Front Wheel Assist Option

The 685C Motor Grader offers agencies and contractors enhanced pulling power with its front wheel assist providing all-wheel traction. Shown with hoses removed for clarity.

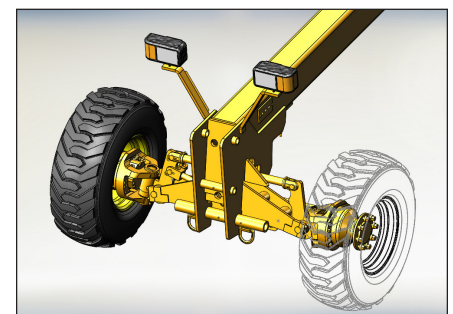

Articulated Design

The LeeBoy 685C Motor Grader is designed with an 18° articulation in either direction. This offers additional mobility that can accomplish the most demanding grading tasks.



Enclosed Turnable Design

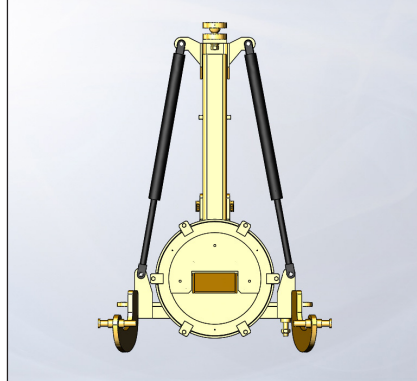

The turntable – designed and engineered by LeeBoy – is enclosed in a sealed housing which prevents wear from dirt and moisture. This advanced design provides quick and easy adjustments and keeps the turntable true for fine grading.

Rear Scarifier

With its steel teeth, the rear-mounted scarifier gives the operator the ability to rip or loosen hardened surfaces.



Configuration Checklist

685C

110 hp (82.1 kw) Cummins Tier 3 Turbo Diesel Engine	✓
11' (3.35 m) Sliding/Tilting Moldboard	✓
Vandalism Protection Package	✓
Leaning Front Wheels	✓
Dual Stage Air Cleaner	✓
Operating Light Package	✓
Electronic Gauge Package	✓
Suspension Seat	✓
Fail Safe Braking System	✓
Rear Mount Scarifier	✓
Beacon	✓
Blade Float Control	✓
Back-up Alarm	✓
Choice of Cab or Canopy (both ROPS/FOPS)	✓
Front Wheel Assist	optional
Rear Washer/Wiper (cab only)	optional
12' (3.66 m) Sliding Moldboard	optional
Circle Side Shift	optional
7' (2.13 m) Front Blade	optional
Front-mounted Scarifier	optional
Air Conditioning	optional
Dead Engine Steering	optional
Cold Weather Engine Package	optional
Radio/CD/Speaker	optional

The 685C Motor Grader is suited for grading and fine grading applications.



Specifications

		685C Motor Grader
ENGINE		
Make	Performance	Cummins Tier 3 Diesel Engine 110 hp (82.1 kw) @ 2,100 rpm
DIMENSIONS		
Weight		17,000 lbs (7,711 kg)
Length		23'4" (7.11 m)
Width		7'8" (2.34 m)
		9'7" (2.92 m)
Height with Cab and Beacon		9'11" (3.02 m)
MOLDBOARD		
Width		11' (3.35 m)
Height		1'6" (0.46 m)
Side Shift		3' (0.91 m)
Tilt		30°
Lift Above Ground		1'1" (0.33 m)
Penetration		1'2" (0.36 m)
Rotation		64°
CAPACITIES		
Fuel		31 gallons (117 l)
Hydraulic		27.5 gallons (104 l)

LeeBoy makes continuous improvements to all its products and reserves the right to change specifications without notice. Photos and illustrations may contain standard and optional equipment.

685C Motor Grader, OX



Other Members of the LeeBoy Family of Products...



8515C Asphalt Paver



250 Asphalt Distributor



3000 Force Feed Loader



Check us
out online

www.LeeBoy.com

"LeeBoy is dedicated to providing top quality parts and service support on every unit sold."

